

Static Ultrasonic Meter for Heat or
Cooling applications
Residential + Local supply

Landis+
Gyr+
manage energy better

T230

Catalog sheet



Date: December 2010
Filename: UH508 101
Landis+Gyr GmbH

Outstanding features

Ultrasonic meter to measure flow and energy in a heat or cooling circuit with water using the ultrasonic principle.

Important features are:

- **Non-wearing due to non-moving parts**
- **Measuring range of flow 1:100 according to EN 1434, 1:1000 total range**
- **Fast, intelligent temperature measuring interval**
- **Any mounting orientation, horizontal, vertical, overhead**
- **Easy installation and reading**
- **Removable electronic unit**
- **Large, easy readable display**
- **Power measurement with maximum values**
- **2 set days for in whole 24 months (can be parameterized)**
- **Yearly set day (can be parameterized)**
- **Operated by battery up to 11 years**
- **Optical interface according to EN 62056-21**
- **Communication modules for remote readout and system connection**
- **Self diagnostics**

Contents

1	Product description	4
2	Application	4
3	Meter design	4
3.1	Method of operation	4
3.2	Metering accuracy according to EN 1434	5
3.3	Interfaces of the electronic unit (communication)	5
3.4	LCD display content	6
3.5	Operating elements	6
3.6	Display concept - loops	7
3.7	Previous year values	8
3.8	Monthly values	8
3.9	Special versions	8
3.10	Power supply	8
3.11	Temperature sensors	8
3.12	Approvals	8
3.13	Parameterization	9
4	Technical data – meter	9
4.1	Technical data – electronic unit	9
4.2	Technical data – volume measuring unit	9
5	Preferred types ULTRAHEAT® T230 Heat Meters	10
6	Preferred types ULTRACOLD® T230 Cooling Meters	11
7	Ordering data	12
8	Accessories for T230	13
9	Pressure loss characteristics	14
10	Dimensions	15

1 Product description

This meter is a measuring instrument for physically correct recording of energy consumption. The device consists of a high-tech plastic volume measuring unit, two permanently connected temperature sensors, and an electronic unit that calculates the energy consumption from the volume and temperature difference.

The meter can be installed and read out easily. Due to its excellent combination of high accuracy, no maintenance and long life time, the T230 contributes to keep the annual operating costs to a minimum.

2 Application

The T230 meter is used to measure thermal energy in apartments. It is available as heat or cooling meter.

3 Meter design

The meter consists of an electronic unit, a volume measuring part and two temperature sensors. The electronic unit is equipped with long-term batteries, that enables an operation of up to 11 years.

3.1 Method of operation

The volume detection works with non-wearing ultrasonic measurement principle without mechanical moving parts.

The quantity of energy transferred from the medium to the consumer over a defined period of time is proportional to the temperature difference between the flow and return and the volume of water that has passed through.

The **water volume** is measured in the measuring tube by ultrasonic pulses which are transmitted in the direction of flow and against the direction of flow. Downstream, the time difference between the transmitter and receiver is reduced, upstream it is increased. The water volume is then calculated using the measured values of the time difference.

The **flow and return temperature** are measured by platinum resistors.

The water volume and the temperature difference between flow and return are multiplied and its product integrated. The result which is the consumed **quantity of thermal energy** is stored and displayed in the physical **units kWh/MWh or MJ/GJ**, the volume in **m³**.

The T230 uses an **intelligent, adaptive temperature-measuring interval**. With changing system conditions (e.g. rapid increase of the flow), the T230 changes for a certain time on a fast temperature-measuring interval. Thus the meter always adapt itself to the current situation and records the system temperature "ultra precise".

Electronic unit

A standard electronic unit is used for all measuring tubes with an integrated service unit.

3.2 Metering accuracy according to EN 1434

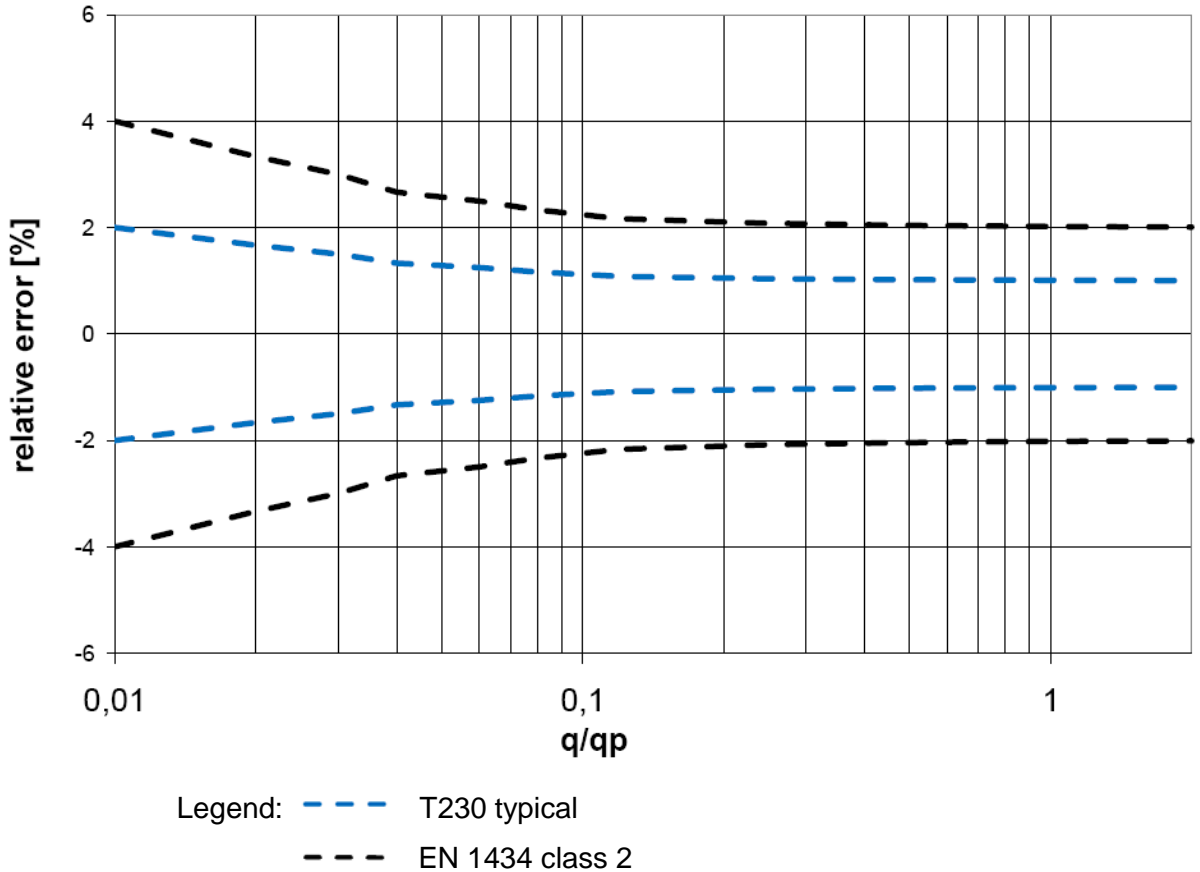

The diagram shows the typical accuracy of the T230 in comparison with the error limits according to EN 1434 class 2. The T230 is either available in class 2 or 3.

3.3 Interfaces of the electronic unit (communication)

The T230 is standard equipped with an optical interface according to EN 62056-21, e.g. for connection of service software.

In addition the communication option M-Bus can be ordered:

Display in the LCD	M-Bus
Norm	EN 1434-3, 13757-2 and 3
Voltage	50 V maximum
Current consumption	1 M-Bus-load (1,5 mA)
Addressing	primary or secondary
Speed	300 or 2400 Baud
Readout frequency	more than 1/min.
Connection	1.5 m connection cable

Under the mentioned conditions the battery lifetime remains unchanged.

3.4 LCD display content

The T230 has a big, well arranged LCD-Display with 7 digits to represent different values (e.g. energy or volume). The new activity indicator enables to recognize a positive flow with a single glance at the display. Icons for previous year values and previous month values complete the clear and easy display concept.

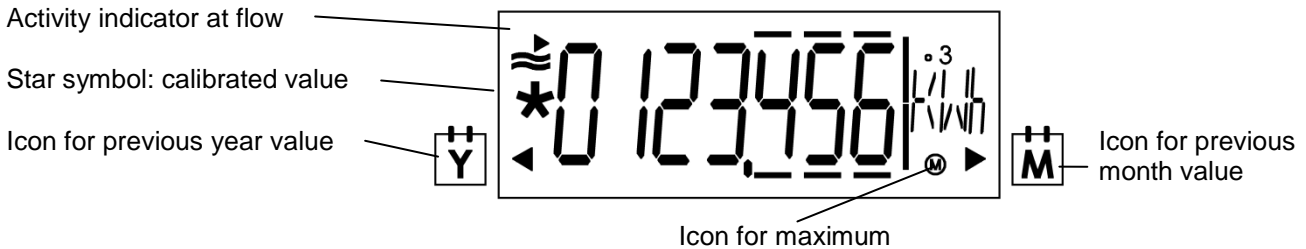

The meter display is subdivided into several loops and may differ from the standard shown in 3.6. By a „short press“ (< 2 sec.) the current loop is passed through line by line. After the last line the first line is displayed again. By a „long press“ (> 3 sec.) the first line of the next loop is displayed. After the last loop the first is shown again.

The arrow icons mark the display of a stored value of the previous year or previous month. A calibrated value (e.g. energy) is marked on the display through a star symbol. The places after the decimal point of displayed values are indicated by a surrounding frame.

3.5 Operating elements



3.6 Display concept - loops

LOOP 0	LOOP 1	LOOP 2	LOOP 3	LOOP 4
User loop	Current values	Previous month values	General/communication	Other
Energy	Current flow	Saving day	Device number, 7-digits	Date
Volume	Current thermal power	Energy and volume on set day	Optional interface	Time
Segment test	Current flow...	Missing time on set day	Primary address (only for M-Bus)	Code entry for test/para operation
In case of error message with error code	and return temperature alternating in 2 sec. cycle	Max. flowrate on the set day, at 2s intervals with date stamp	Secondary address 7-digit (only for M-Bus)	
	Operating time	Max. power on the set day, at 2s intervals with date stamp	Yearly set day	
	Missing time	Max. flow temperature on the set day, at 2s intervals with date stamp	Monthly set day	
	Time with flow rate	Max. return temperature on the set day, at 2s intervals with date stamp	Firmware version	
			CRC-Code part which requires calibration	

Standard content of the user loop (Loop 0)

e.g. energy, volume, segment test and error messages

Standard content of the service loop 1 (Loop 1)

e.g. instantaneous values of flow, power, flow- and return temperature, operation time, etc.

Standard content of the service loop 2 (Loop 2)

e.g. previous month values of energy, volume, maxima, etc.

Standard content of the service loop 3 (Loop 3)

e.g. device number, communication interface, M-Bus primary address, yearly set day, monthly set day, etc.

Standard content of the service loop 4 (Loop 4)

e.g. date, time, code input for the configuration mode, etc.

3.7 Previous year values

The electronic unit stores the meter readings for quantity of energy, volume, missing time, and operating time with flow as well as the current maxima for the flowrate, power, flow- and return temperature with their date stamps on a yearly set day.

The set day for previous year values can be parameterised.

3.8 Monthly values

The electronic unit stores the meter readings for quantity of energy, volume, missing time, and operating time with flow as well as the monthly maxima for the flowrate, power, flow- and return temperature with their date stamp for up to 24 months on the set day of each month.

The set day for previous monthly values can be parameterised.

In addition for 24 months, a second programmable monthly set day exists, where the energy and the volume is stored.

3.9 Special versions

- Heat meter for **installation in flow**
- Version as **cooling meter** for water
- Cable lengths for temperature sensors: 1,5 m (standard), 5 m (optional)

3.10 Power supply

The meter can be supplied either with a 6 year or a 11 year battery.

3.11 Temperature sensors

Permanent installed temperature sensors (Ø 5,2x45 mm) PT500 in 2-wire types are used.

The sensors are available in various cable lengths. A sensor is always integrated in the measuring tube.

3.12 Approvals

- EN 1434 class 2 or 3
 - MID (European Measuring Instruments Directive 2004/22/EG)
 - national approval in various countries
-

3.13 Parameterization

The parameterization can be done directly on the meter or with the service software via optical interface.

4 Technical data – meter

4.1 Technical data – electronic unit

Temperature range	0 ... 120°C
Temperature difference range $\Delta\Theta$	3 ... 80 K
Temperature response threshold	0,2 K
Thermal coefficient	gliding compensated
t-measurement error without sensor (EN 1434)	$(0,5 + \Delta\Theta_{\min}/\Delta\Theta)\%$, max. 1,5% at $\Delta\Theta = 3$ K
Ambient temperature	5...55°C
Permissible humidity	< 93% r.h. at 25°C (without condensation)
Environment class	E1, M1
Protection type	IP54
Dimensions	116 x 70,4 mm ²
Control cable	1,5 m

4.2 Technical data – volume measuring unit

Nominal flowrate	q_p	0,6	1,5	2,5	m ³ /h
Metrological class		1:100	1:100**	1:100	
Maximum flow	q_s	1,2	3	5	m ³ /h
Minimum flow	q_i	6	15	25	l/h
Response threshold		1,2	3	5	l/h
Pressure loss at q_p :					
110 mm thread ***	Δp	75	135	----	mbar
130 mm thread ***	Δp	----	135	165	mbar
Flowrate at $\Delta p = 1$ bar	K_v	2,2	4,1	6,2	m ³ /h
Mounting orientation	any				
Temperature range		5 ...90°C *			
Maximum temperature	t_{\max}	90°C			
Nominal pressure	PN	16			
Protection class		IP65			
Tolerable measurement error		According to EN 1434 (class 2 or 3)			

*** tolerance for pressure loss +/- 5%

** also available in 1:125

* national approvals may differ

5 Preferred types ULTRAHEAT® T230 Heat Meters

1) Nominal flowrate qp 0,6 m³ - 2,5 m³

Ultrasonic Heat Meter ULTRAHEAT®:

- Standard design with threaded joint

- installation in return (lower temperature)
- removable electronic unit with 1,5 m control cable
- return sensor integrated in volume measuring unit
- temperature sensor with cable length 1,5 m
- 6-year-battery
- compliant to MID cl. 3
- display in MWh

Nominal size qp	Overall length mm	Connection	Pressure stage PN	Sensor type/ length mm	Order number
qp 0,6	110	G 3/4	16	5,2 x 45	T230-A05C-DE00-P 0H-A0-M3B
qp 1,5	110	G 3/4	16	5,2 x 45	T230-A21C-DE00-P 0H-A0-M3B
Plus					
Mounting element for temperature sensor DS, M 10x½" with Cu-seal					WZT-A 12
Fitting G ¾ x R ½ , mounting kit (couple) with EPDM-seals					T23-E34

- Standard design with threaded joint

- installation in return (lower temperature)
- removable electronic unit with 1,5 m control cable
- return sensor integrated in volume measuring unit
- temperature sensor with cable length 1,5 m
- 6-year-battery
- compliant to MID cl. 3
- display in MWh

Nominal size qp	Overall length mm	Connection	Pressure stage PN	Sensor type/ length mm	Order number
qp 1,5	130	G 1	16	5,2 x 45	T230-A26C-DE00-P 0H-A0-M3B
qp 2,5	130	G 1	16	5,2 x 45	T230-A36C-DE00-P 0H-A0-M3B
Plus					
Mounting element for temperature sensor DS, M 10x½" with Cu-seal					WZT-A 12
Fitting G 1 x R ¾ , mounting kit (couple) with EPDM-seals					T23-E1

6 Preferred types ULTRACOLD® T230 Cooling Meters

1) Nominal flowrate q_p 0,6 m³ - 2,5 m³

Ultrasonic Cooling Meter ULTRACOLD®:

- Standard design with threaded joint

- installation in return (higher temperature)
- removable electronic unit with 1,5 m control cable
- return sensor integrated in volume measuring unit
- temperature sensor with cable length 1,5 m
- 6-year-battery (2xAA cells)
- compliant according to national regulations, e.g. Germany
- display in MWh

Nominal size q_p	Overall length mm	Connection	Pressure stage PN	Sensor type/ length mm	Order number
q_p 0,6	110	G 3/4	16	5,2 x 45	T230-G05C-DE00-P 0H-A0-CLB
q_p 1,5	110	G 3/4	16	5,2 x 45	T230-G21C-DE00-P 0H-A0-CLB
Plus					
Mounting element for temperature sensor DS, M 10x1/2" with Cu-seal					WZT-A 12
Fitting G 3/4 x R 1/2 , mounting kit (couple) with EPDM-seals					T23-E34

- Standard design with threaded joint

- installation in return (higher temperature)
- removable electronic unit with 1,5 m control cable
- return sensor integrated in volume measuring unit
- temperature sensor with cable length 1,5 m
- 6-year-battery (2xAA cells)
- compliant according to national regulations, e.g. Germany
- display in MWh

Nominal size q_p	Overall length mm	Connection	Pressure stage PN	Sensor type/ length mm	Order number
q_p 1,5	130	G 1	16	5,2 x 45	T230-G26C-DE00-P 0H-A0-CLB
q_p 2,5	130	G 1	16	5,2 x 45	T230-G36C-DE00-P 0H-A0-CLB
Plus					
Mounting element for temperature sensor DS, M 10x1/2" with Cu-seal					WZT-A 12
Fitting G 1 x R 3/4 , mounting kit (couple) with EPDM-seals					T23-E1

In the selection of Cooling Meters and other differing types we are happy to help.
All available options please refer to the order data overview.

7 Ordering data

Order codes (type number key)

	Mandatory data for the order designation (label plate data)										Mandatory data for Hardware- dependent features																	
Type code:	T	2	3	0	-	X	X	X	X	-	X	X	X	X	-	X	-	X	X	-	X	X	-	X	X	X		
1. Meter type and mounting location																												
2. Nominal flowrate																												
3. Control cable/ type/ electronic unit																												
4. Country/ where used																												
5. Manufacturer's label																												
6. Sensor type and connection method																												
7. Sensor design																												
8. Power Supply																												
9. Communication																												
10. Calibration/ conformity																												
11. Energy unit																												

Order codes for label plate data	
1. Type of meter and mounting location	Code
Heat meter for mounting in return	A
Heat meter for mounting in flow	B
Cooling meter (medium water) for mounting in return	G
Cooling meter (medium water) for mounting in flow	H
2. Nominal flowrate	Code
Nominal flowrate 0,6 m ³ /h, length 110 mm, nominal pressure PN16, connection G ¾ B	05
Nominal flowrate 1,5 m ³ /h, length 110 mm, nominal pressure PN16, connection G ¾ B	21
Nominal flowrate 1,5 m ³ /h, length 130 mm, nominal pressure PN16, connection G 1 B	26
Nominal flowrate 2,5 m ³ /h, length 130 mm, nominal pressure PN16, connection G 1 B	36
3. Control cable/ type/ electronic unit	Code
Split version with 1,5 m control cable	C
4. Country/ where used	Code
Dial plate for Germany (German)	DE
Dial plate English neutral	EN
5. Manufacturer's label	Code
Logo Landis+Gyr	00
6. Sensortype and connection method	Code
Sensor Pt500, not removable, directly mounted in the measuring tube	P
Hardware-dependent features	
7. Sensor type	Code
16 bar/90°C/ Ø5,2 x 45mm, cable length 1,5 m	0H
16 bar/90°C/ Ø5,2 x 45mm, cable length 5 m	0J

8. Power supply	Code
Battery for 6 years (1 x AA)	A
Battery for 11 years (2 x AA)	E
9. Communication	Code
Without	0
M-Bus Standard	B
10. Calibration / conformity	Code
Certified acc. to national regulations	CL
Compliant with CEN 1434 class 2	T2
Compliant with CEN 1434 class 3	T3
Compliant to MID class 2	M2
Compliant to MID class 3	M3
11 Energy unit	Code
Display: kWh	A
Display: MWh with 3 decimal places	B
Display: MJ	C
Display: GJ with 3 decimal places	D

- further information and all instructions are currently in the Internet at www.landisgyr.com

8 Accessories for T230

Temperature sensor accessories

Description	Order No.
Adapter for DS-sensor M 10 x 1 mm x G $\frac{3}{8}$ B, with sealing disk G $\frac{3}{8}$ Cu	WZT-A38
Adapter for DS-sensor M 10 x 1 mm x G $\frac{1}{2}$ B, with sealing disk G $\frac{1}{2}$ Cu	WZT-A12
Adapter for DS-sensor M 10 x 1 mm x G $\frac{3}{4}$ B, with sealing disk G $\frac{3}{4}$ Cu	WZT-A34
Ball valve Rp $\frac{1}{2}$ for the installation of sensor \varnothing 5,2 x 45 mm with M10x1; suitable for PN16	WZT-K12
Ball valve Rp $\frac{3}{4}$ for the installation of sensor \varnothing 5,2 x 45 mm with M10x1; suitable for PN16	WZT-K34
Ball valve Rp 1 for the installation of sensor \varnothing 5,2 x 45 mm with M10x1; suitable for PN16	WZT-K1

Volume measuring units

Description	Order No.
Mounting kit, couple fittings G $\frac{3}{4}$ x R $\frac{1}{2}$, with EPDM sealings	T23-E34
Mounting kit, couple fittings G 1 x R $\frac{3}{4}$, with EPDM sealings	T23-E1
10 pcs EPDM-sealing for mounting the volume measuring unit $\frac{3}{4}$ " (spare part)	T23-34EPDM10
10 pcs EPDM-sealing for mounting the volume measuring unit 1" (spare part)	T23-1EPDM10

Further

Description	Order No.
10 pcs wall adapter for mounting of the electronic unit on the wall, with screws and dowels	T23-WA10

9 Pressure loss characteristics

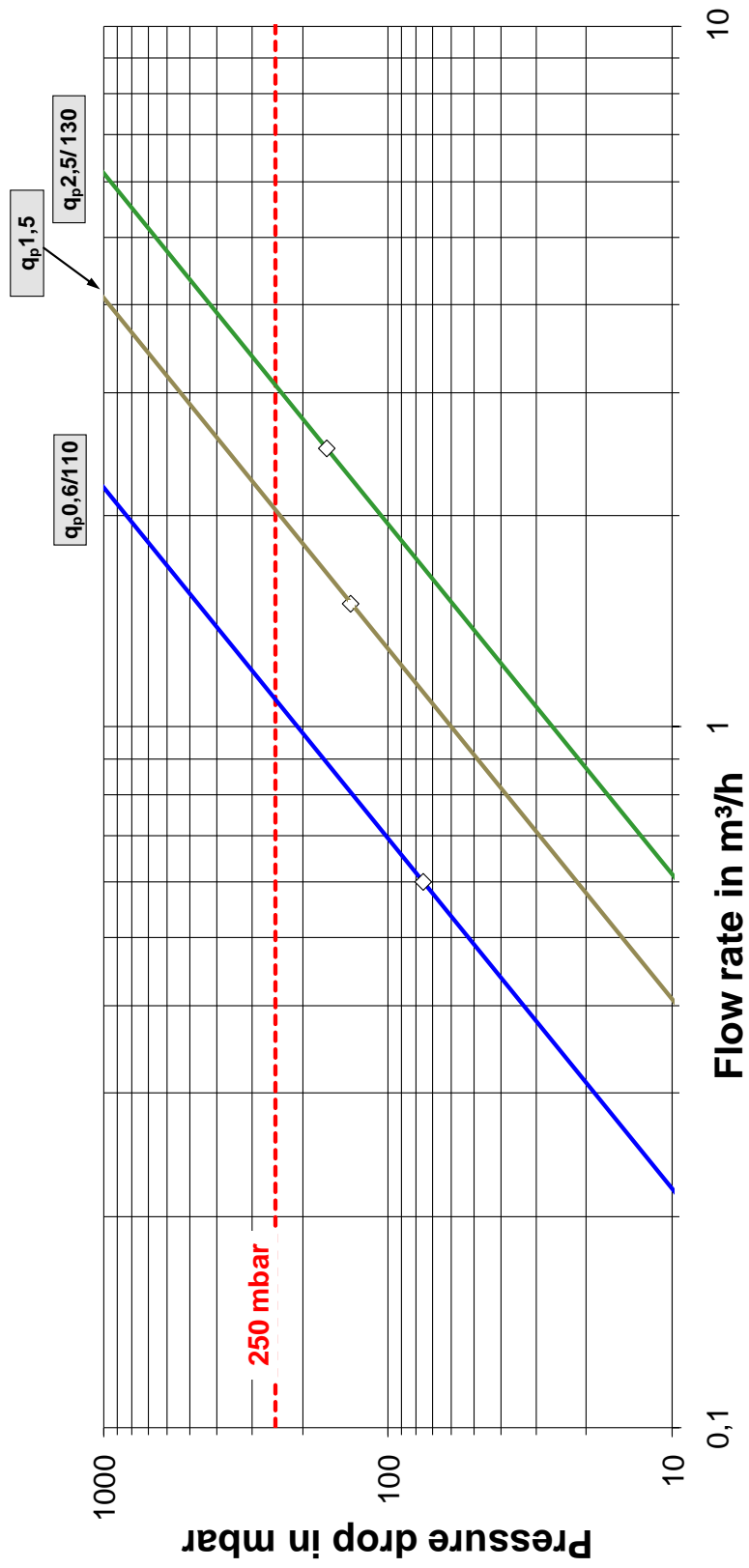

10 Dimensions

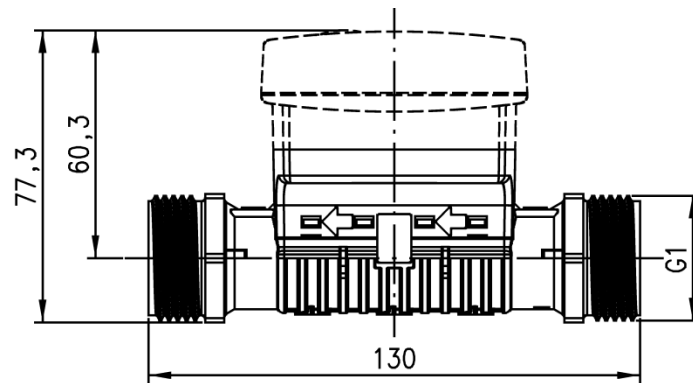
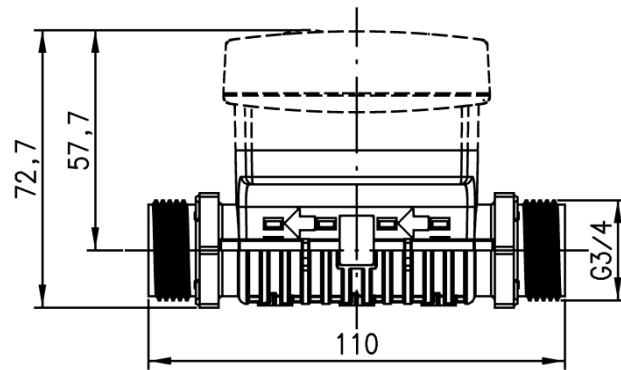

Order-No.	qp m³/h	PN bar	Overall length in mm
T230-x05	0,6	16	110
T230-x21	1,5	16	110
T230-x26	1,5	16	130
T230-x36	2,5	16	130

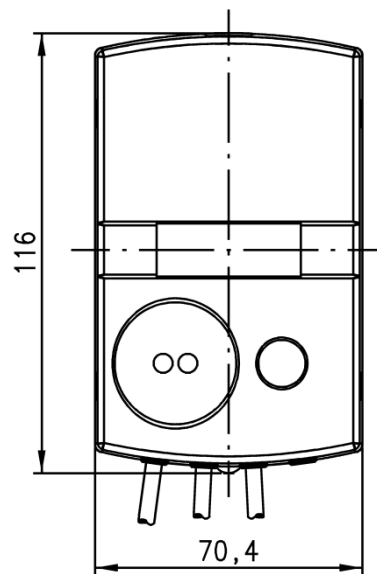

Electronic unit (front view)

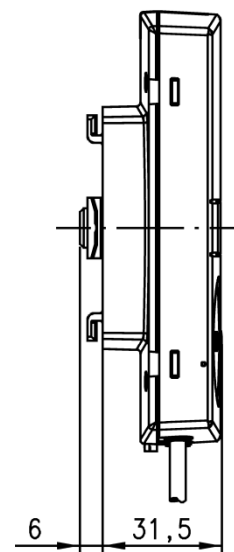

Electronic unit (side view)

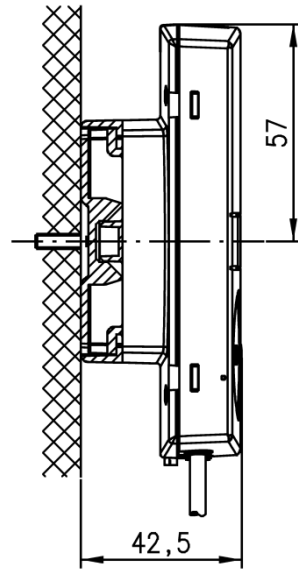

Wall mounting

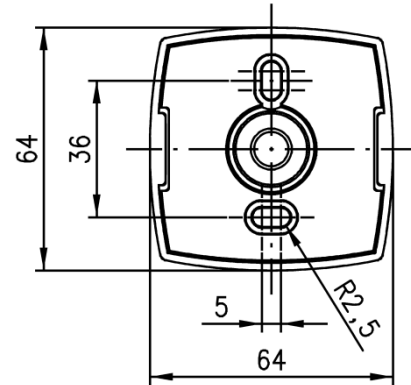

Wall adapter (view from above)

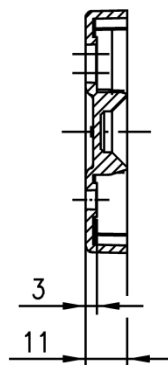

Wall adapter (side view)

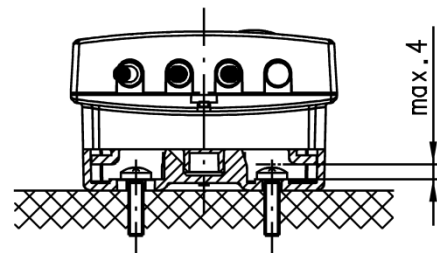
Maximum screw head height
(if using the wall bracket)

Please note: The wall adapter is not included in the delivery amount of the meter! It can be ordered as an accessory.